

THANK YOU FOR CHOOSING CRUSHER!

PROTECT YOURSELF AND OTHERS FROM POTENTIAL INJURY AND PROPERTY DAMAGE OR LOSS. PAY CLOSE ATTENTION TO ALL INSTRUCTIONS, WARNINGS, CAUTIONS, AND NOTICES REGARDING THE INSTALLATION, USE, AND CARE OF THIS PRODUCT.

⚠ WARNING

THIS INDICATION ALERTS YOU TO THE FACT THAT IGNORING THE CONTENTS DESCRIBED HEREIN CAN RESULT IN POTENTIAL DEATH OR SERIOUS INJURY.

NOTICE

This indication alerts you to the fact that ignoring the contents described herein may negatively affect product performance and functionality or damage the product itself or the product to which it is being attached.

THIS PRODUCT IS NOT LEGAL FOR SALE OR USE ON POLLUTION CONTROLLED VEHICLES.

ENSURE THAT THE FOLLOWING PARTS HAVE BEEN INCLUDED IN THE KIT:

- 1 Crusher Maverick Air Cleaner Assembly
- 1 Filter Element
- 1 Hardware Kit containing:
 - 5 1/4"-20 x 3/4" Socket Head Cap Screws
 - 3 1/4"-20 x 1" Socket Head Cap Screws
 - 3 1/4"-20 x 1-1/4" Socket Head Cap Screws — NOT USED
 - 1 Air Lock Ring
 - 2 1/8" Straight Fittings
 - 1 Dual Velocity Ring
 - 1 Backing Plate
- 2 Breather Bolts
- 2 Formed Breather Hoses
- 1 Installation Instructions

YOU WILL ALSO NEED:

Set of hex wrenches, set of sockets and a ratchet, set of combination wrenches

NOTICE

These installation instructions contain important information. Ensure that the end user receives this copy and is aware of its importance for future use.

⚠ WARNING

THE END USER'S SAFETY DEPENDS UPON PROPER INSTALLATION OF THIS PRODUCT. IF A STEP IN THESE INSTRUCTIONS IS NOT WITHIN YOUR CAPABILITIES OR YOU DO NOT HAVE THE CORRECT TOOLS, HAVE YOUR DEALER PERFORM THE PROCEDURE. IMPROPER INSTALLATION OF THIS PRODUCT COULD RESULT IN DEATH OR SERIOUS INJURY.

ACCIDENTAL VEHICLE START-UP COULD CAUSE DEATH OR SERIOUS INJURY, REMOVE THE MAIN FUSE BEFORE PROCEEDING.

WORKING AROUND THE SHARP EDGES OF THE CYLINDER-HEAD FINS EXPOSES YOUR HANDS TO INJURY. WEAR PROTECTIVE GLOVES TO PREVENT SERIOUS INJURY.

⚠ WARNING

INSTALLATION REQUIRES CONTACT WITH THE EXHAUST SYSTEM. ENSURE THAT THE EXHAUST SYSTEM HAS FULLY COOLED BEFORE BEGINNING TO PREVENT INJURY.

SOME PICTURES DEPICT TWIN CAM ENGINES, THE PROCEDURE IS THE SAME FOR SPORTSTER.

STEP 1 Read and understand all **STEPS** in the instructions before starting the installation. Park the motorcycle on a hard, level surface and turn **IGN OFF**. Allow the engine and exhaust system to cool. Remove the main fuse.

STEP 2 Prepare a soft, sturdy work surface within arm's reach of the motorcycle.

STEP 3 Refer to **PIC 1**. Remove the existing air cleaner assembly; set it aside, it will not be reused. Carefully remove any remaining gasket material from the throttle body flange.

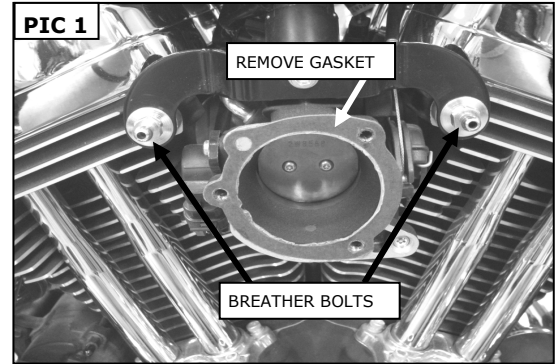

STEP 4 Refer to **PIC 1**. Locate the included Breather Bolts; thread them into the cylinder heads.

STEP 5 Refer to **PIC 2**. Locate the two (2) included 1/8" Straight Fittings and Backing Plate. Thread the Fittings into the Backing Plate as shown in **PIC 2**.

Connect the included Breather Hoses to the Fittings.

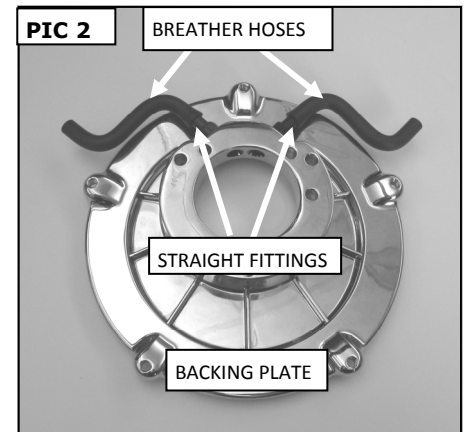

STEP 6 Locate the three (3) included 1/4"-20 X 1" Socket Head Cap Screws and set them within arm's reach of the work area.

Refer to **PIC 3**. Locate the included Air Lock Ring; align it with the throttle body flange as shown in **PIC 3**; align only the mounting holes.

Sandwich the Ring against the flange with the Backing Plate assembly.

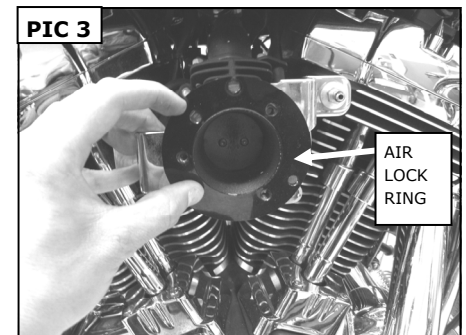

STEP 7 Align the holes and secure the Backing Plate to the throttle body with the three Screws from **STEP 6**. Tighten the three Screws.

STEP 8 Refer to **PIC 4**. Locate the included Dual Velocity Ring.

Position the vent hole at 10 o'clock and press the Ring into place. Ensure that the ring is pressed in flush with the Backing Plate; it should "snap" into place.

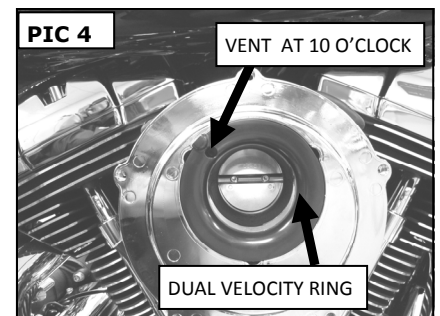

STEP 9 Refer to **PIC 5**. Connect the Breather Hoses to the Breather Bolts.

STEP 10 Locate the included Crusher Maverick Air Cleaner Cover, Filter Element and five (5) 1/4-20 x 3/4" Socket Head Cap Screws; set it all within arm's reach of the work area.

Install the Filter Element over the Backing Plate.

STEP 11 Refer to **PIC 6**. Place the included Mesh and Beauty Ring over the Filter Element.

Refer to **PIC 7**. Secure the Cover to the Backing Plate using the 3/4" Screws.

Ensure that the Mesh and Beauty ring remain aligned, then tighten the five screws in an alternating pattern.

STEP 12 Reinstall the main fuse. Double check all hose connections. Rotate the throttle open; ensure it returns correctly before starting the motorcycle.

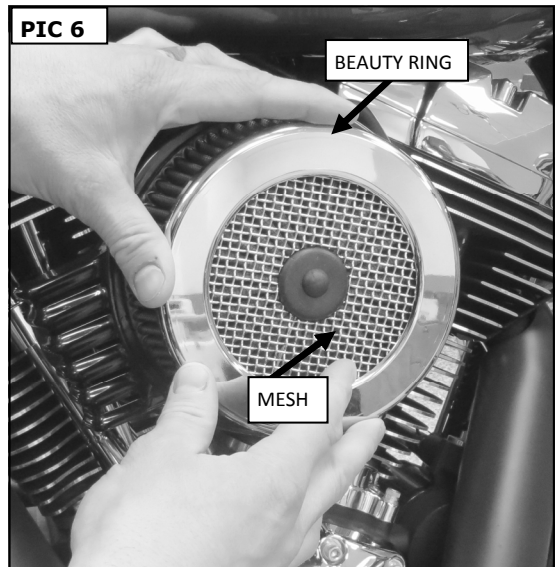
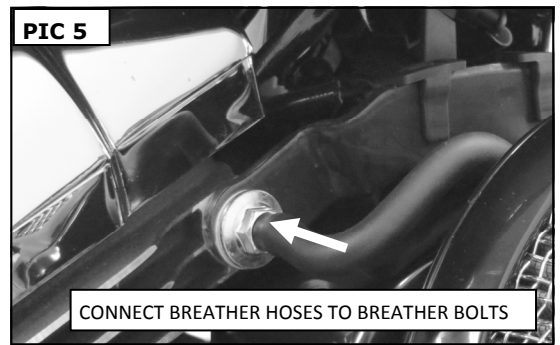

NOTICE

Some high performance air cleaners extend beyond the OEM unit to achieve smoother air flow and better performance. Riding position may be affected. It is important to familiarize yourself with the new riding position.

Follow K&N recommendations for proper use and cleaning of the air filter element. K&N Filter Care Kit (p/n 85 available at kuryakyn.com)

⚠ WARNING

FAILURE OF THE THROTTLE TO RETURN COULD RESULT IN LOSS OF CONTROL CAUSING SERIOUS INJURY OR DEATH.

NOTICE

It is the end user's responsibility to ensure that all fasteners (including pre-assembled) are tightened before operation of the motorcycle. Kuryakyn will not provide warranty coverage on products or components lost or damaged due to improper installation or lack of maintenance. Periodic inspection and maintenance are required on all fasteners.

Proper tuning is important. Carbureted bikes should be re-jettied and fuel injected bikes should be tuned with a TTS MasterTune tuning system (calibrations available at www.kuryakyn.com) or Vance & Hines FP3 (calibrations available at <http://fp3.vanceandhines.com/download>) by an experienced tuner, on a dyno, with an exhaust gas analyzer.

LIMITED WARRANTY

Küryakyn warrants that any Crusher products sold hereunder, shall be free of defects in materials & workmanship for a period of one (1) year from the date of purchase by the consumer excepting the following provisions:

1. Küryakyn shall have no obligation in the event the customer is unable to provide a receipt showing the date the customer purchased the product/s.
2. The product must be properly installed, maintained & operated under normal conditions.
3. Küryakyn shall not be liable for any consequential & incidental damages, including labor & paint, resulting from failure of a Küryakyn product, failure to deliver, delay in delivery, delivery in nonconforming condition, or for any breach of contract or duty between Küryakyn & a customer.
4. Crusher products are often intended for use in specific applications. Küryakyn makes no warranty if a Küryakyn product is used in applications other than intended.
5. Crusher electrical products are warranted for one (1) year from the date of purchase by the consumer. L.E.D.'s contained in components of Küryakyn products will be warranted for defects in materials & workmanship for 3 years from the date of purchase where as all other components shall be warranted for one (1) year.
6. Exhaust systems are warranted for manufacturing defects only. There is no warranty on exhaust pipes & mufflers with regard to any discoloration. Discoloration or "bluing" is caused by tuning characteristics, exhaust timing, carburetor jetting, overheating, etc. & is not caused by defective manufacturing.
7. Küryakyn makes no warranty of any kind in regard to other manufacturer's products distributed by Küryakyn. Küryakyn will pass on all warranties made by the manufacturer & where possible, will expedite the claim on behalf of the customer, but ultimately, responsibility for disposition of the warranty claim lies with the manufacturer.
8. Merchandise purchased directly from Internet auction sites or any other third party seller is considered sold as is & shall not carry a Küryakyn warranty. All warranty claims must be directed to the original seller. If unsure please contact the seller to verify they are an authorized Küryakyn retailer.

RETURN POLICY

Merchandise determined to be defective may be returned up to one year from the date of purchase. Returns must be processed through original seller. Returned merchandise for any other reason other than warranty claims must be in like new condition & subject to a 20% restocking fee. All returns are subject to inspection for determination of full or partial credit. Any returned part that shows evidence of being used or installed contrary to manufacturer's instructions, &/or subjected to improper handling, packaging or return shipping by the customer, will not be eligible for exchange, refund or warranty consideration. All returned electrical items will be inspected & tested. If electrical item is deemed functional, no credit will be issued & item will be returned. All sales are final on discontinued or closeout merchandise.

RETURN INSTRUCTIONS

Contact one of our prompt, courteous Customer Service representatives toll free at 866-295-5759. Be sure to have the following information available when you call:

Name

Part number/s to be returned

Copy of original invoice

Reason for return

1. Obtain R.M.A. number which shall remain active & valid for 60 days. (Important: Issuance of R.M.A. does not represent an authorized credit.)
2. Carefully package merchandise to avoid damage during shipment. Depending on its condition, original packaging may not be sufficient.
3. Ship only those items for which the R.M.A. has been issued.
4. Write the R.M.A. number prominently on the outside of package.
5. Ship package freight PREPAID (C.O.D.s will not be accepted) to:

Kuryakyn 454 County Road V V Somerset, WI 54025