

POLARIS RANGER 1000

Winch Mount

PART #101480

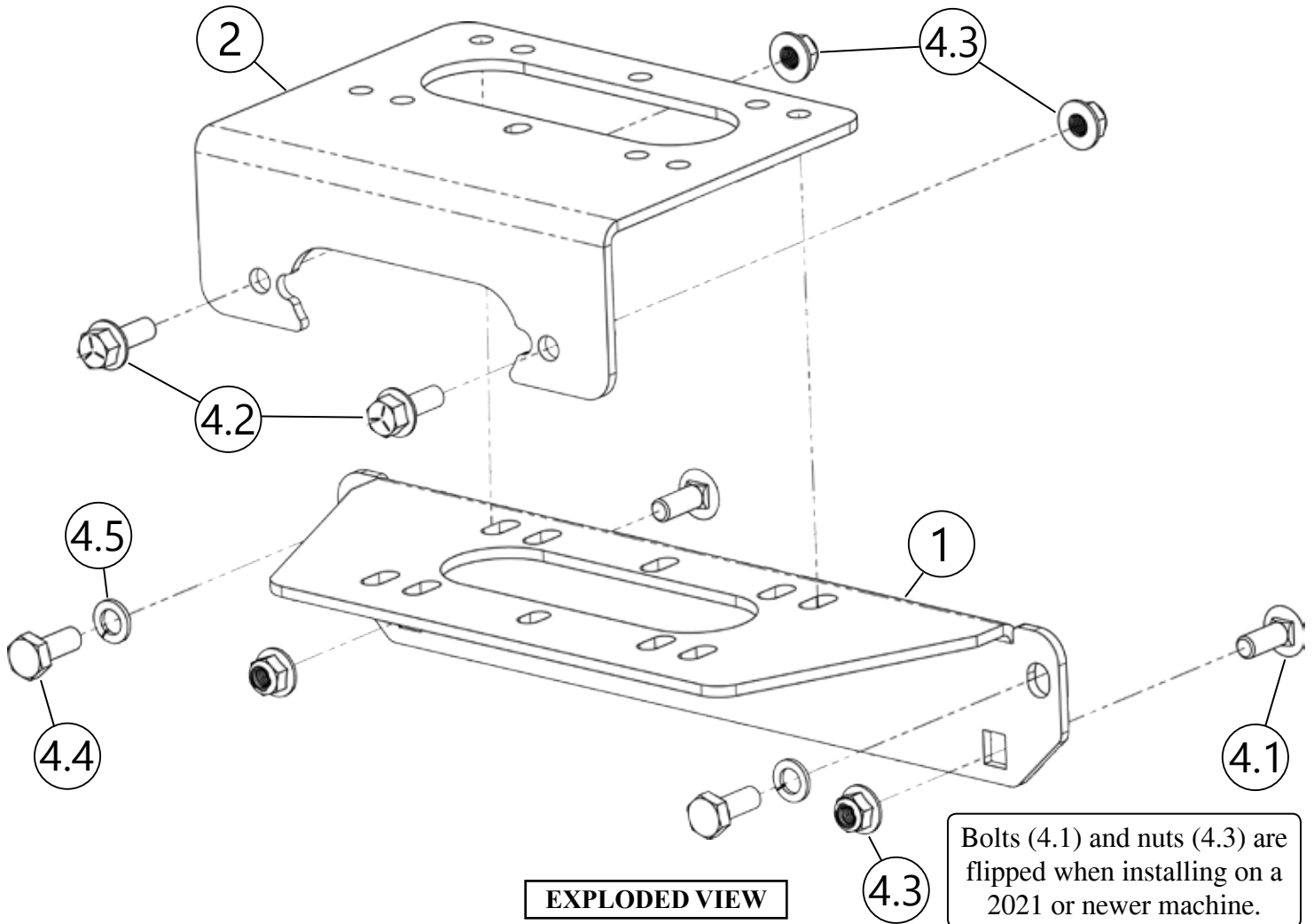

Item #	Qty.	Description
1	1	Winch Mount
2	1	Fairlead Mount
3	1	HK-031 (See Figure 13)
4	1	Hardware Kit (HK-339)

Item #	Qty.	Description
4.1	2	3/8"-16 x 1.00 Carriage Bolt
4.2	2	3/8"-16 x 1.00 Hex Flange Bolt
4.3	4	3/8"-16 Hex Flange Nylock Nut
4.4	2	M10-1.50 x 25 Hex Bolt
4.5	2	M10 Lock Washer



INSTALLATION INSTRUCTIONS

Note: Make sure all hardware needed to complete this mount is in the package. Thoroughly read through and understand the instructions before installing.

1. Remove front bumper by removing OEM bolts (A) found on the back side of the front bumper as shown in **Figure 2 & 3**.
2. Set fairlead mount (2) on top of the winch mount (1) lining up the holes. Loosely attach the winch upside down to the two piece mount using the hardware supplied with the winch. Make sure the cable is spooling off of the top (between the spool and the winch mount) as shown in Figure 5.

Note: For machines with a bumper as shown in **Figure 3**, found on some (NON XP EPS) models, winch mount (1) will need to be installed and fastened to the frame and the front bumper reinstalled before installing fairlead mount (2) and the winch as shown. Fairlead mount (2) will be installed over the front of the front bumper as shown in **Figure 3**.

3. For a 2-Hole mounted winch, use holes (B). For standard 4-Hole winches, use holes (C). For wide 4-Hole winches, use holes (D) as shown in **Figure 4**.

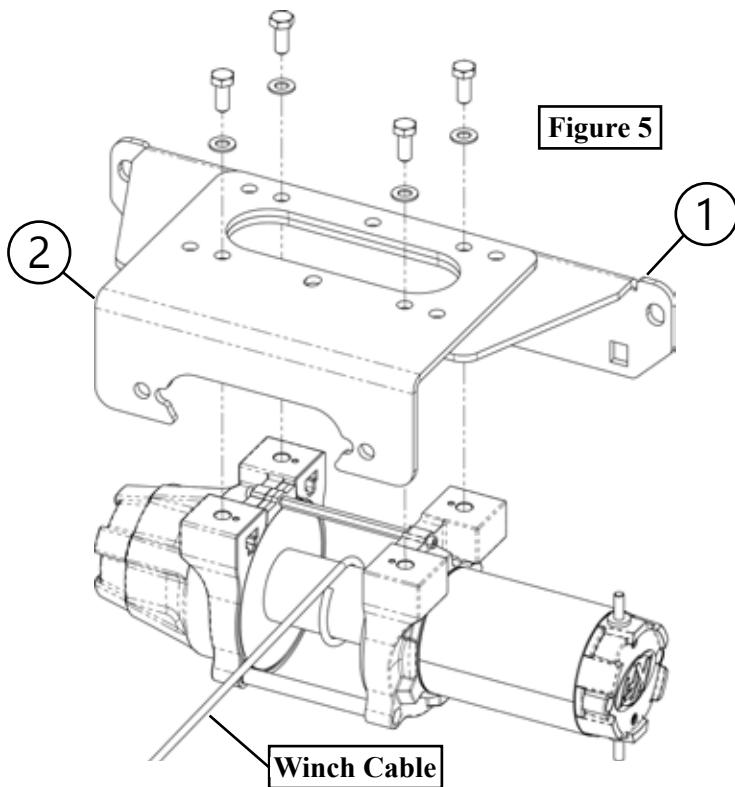
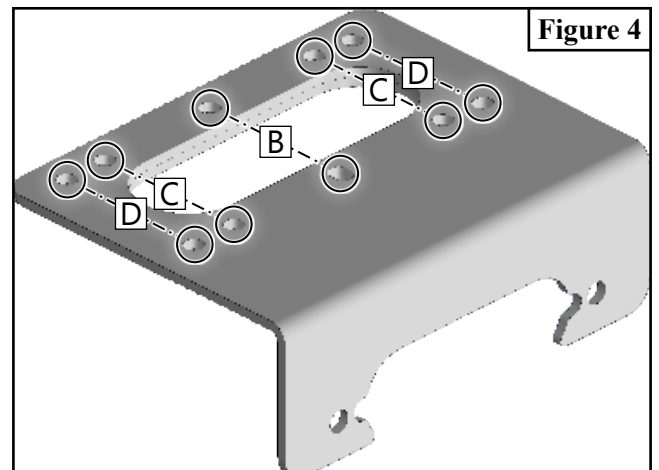
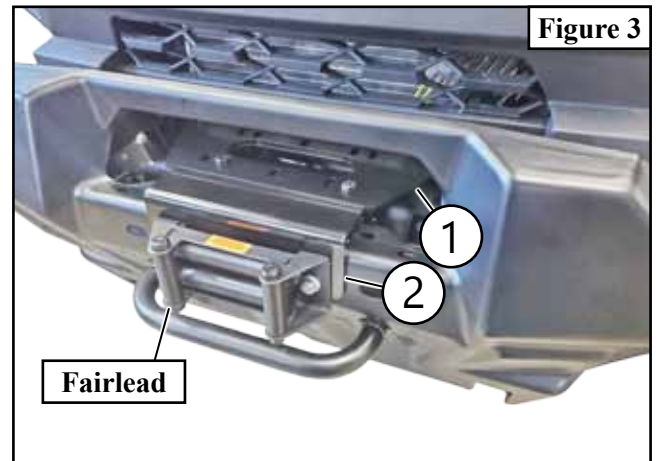
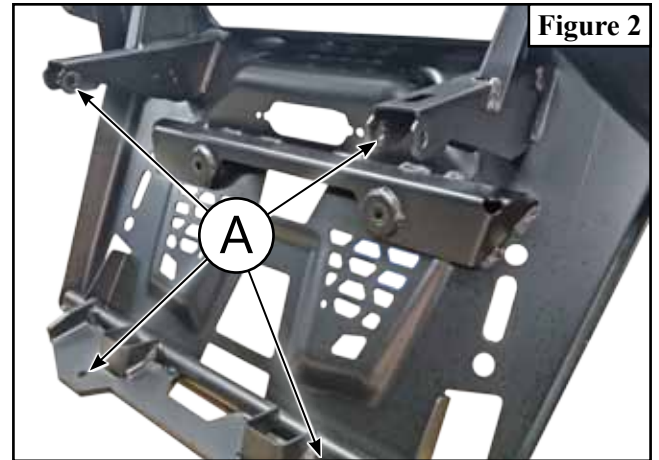
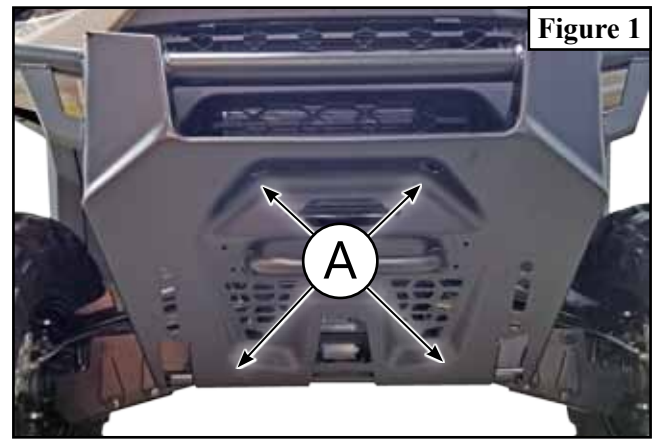

4. Set winch mount (1) in place and secure top of mount using bolts (4.4) and lock washers (4.5) in location (E) as shown in **Figure 6 & 7**.

5. ***For machines 2020 and older,*** attach the bottom of winch mount (1) using bolts (4.1) and nuts (4.3) in location (F) as shown in the **Exploded View** and **Figures 6 & 7**.

6. ***For machines 2021 and newer,*** bolts (4.1) and nuts (4.3) are not needed, but can be installed if desired. In order to install, 2x holes will need to be drilled using a 13/32" drill bit. The bolts (4.1) and nuts (4.3) will be need to be flipped around so the bolt goes in from the front, and the nut goes on from the back. See **Exploded View** and **Figures 6 & 7**.

7. Tighten hardware from steps 4 & (5 or 6).

Note: If the winch terminals contact or come close to contacting the machine, you may need to rotate the motor end cap.

8. Reattach front bumper using OEM bolts (A) removed in step 1.

9. Set the fairlead over fairlead opening in the front bumper lining up holes in fairlead with holes in the bumper. Secure fairlead to the front bumper and fairlead mount (2) using bolts (4.2) and nuts (4.3) as shown in **Figures 8 & 9**.

10. Tighten down the four winch mounting bolts.

Note: You may need to remove the plastic lower grille to gain access to the four winch bolts.

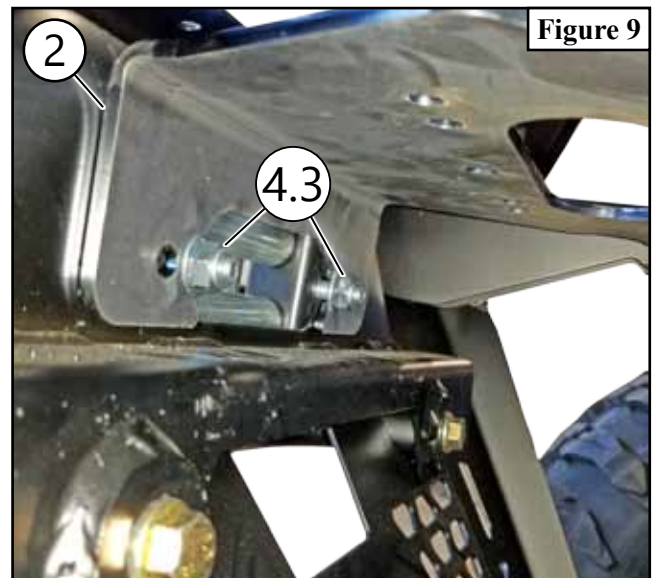
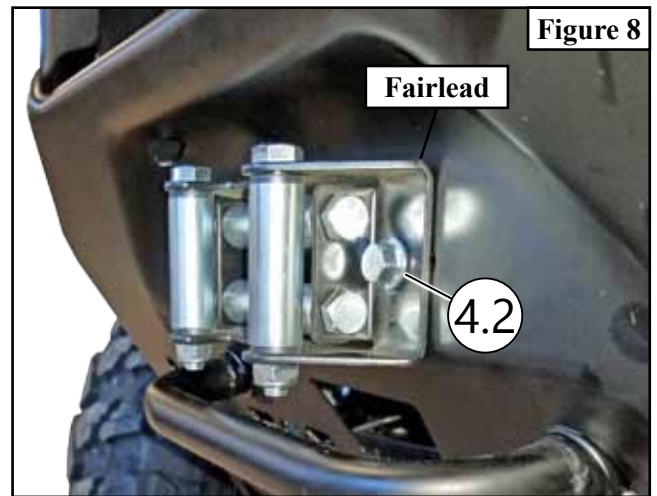
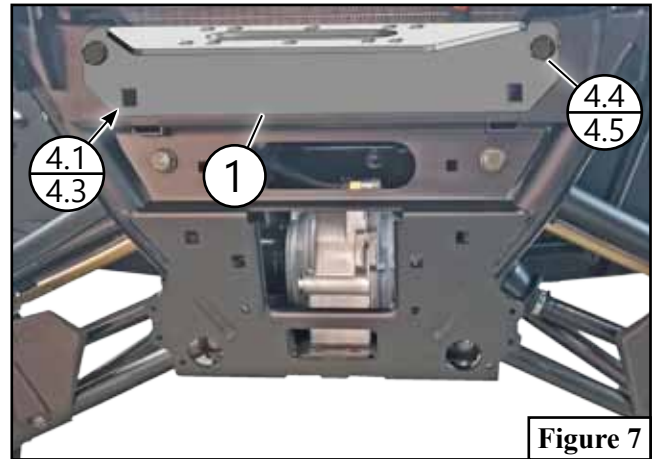
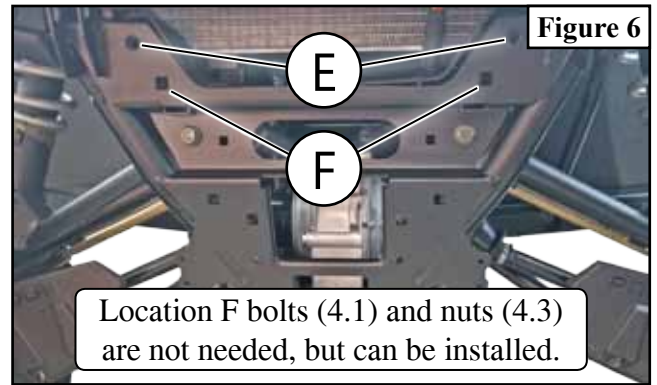

WIRING INSTRUCTIONS

1. Under the hood you will find the contactor location with holes pre-drilled shown in Figure 10.
2. Run the red positive (+) battery wire from the contactor to the positive (+) post on the pulse bar. Run the black ground wire (-) from the contactor to the ground (-) post on the pulse bar shown in Figures 10 & 11.
3. In the center console of the ranger, there are pre-notched holes for the dash rocker switch to mount as shown in Figure 12.

*Note: If your winch only comes with a handbar mounted rocker switch and wish to install it in the dash, assemble per **Figure 13** using hardware kit HK-031 (3).*

4. Attach the ignition fed wire (RED) from your switch to the orange and white wire (H) shown in Figure 10 & 11.
5. For more details on wiring the winch see your winch manual.

