



MOUNTING INSTRUCTIONS

2321-0051 FATS/SLIMS HONDA VT750 SHADOW AERO DETACHABLE

! WARNING

Read and follow these directions carefully.

During installation, make certain that when turning the forks, there can be no interference with wiring or cables AND, that the windshield can not hit the gas tank, through the windshield's full range of adjustment.

This is a detachable windshield, **ALWAYS** make sure the Locking Mechanism is Fully Engaged after installing the windshield!

The improper installation of this kit and related components could result in serious injury or death.

Additional tools required, that are not included in this kit. 7/16" or 11mm wrench, 1/4" drive 8, 10, 13mm sockets and ratchet.

1. Cover gas tank and front fender with towels to avoid damage during installation.

2. Install the two mounting plates onto the windshield using the bottom bolt and the third bolt up. Discard the Nylon Washers. The small tab goes at the bottom, larger tab goes up. *NOTE: Tabs will point away from the headlight when properly installed.* (see Figure 1 and Figure 4)

3. On the Throttle side, locate the two bolts on the lower triple tree that secure the chrome Fork Tins. Using a ratchet with an 8mm and 10mm socket, remove the two bolts.

4. Using the 6mm Allen wrench provided, remove the upper triple tree pinch bolt.

5. Using a 10mm and 13mm socket, loosely install the lower bracket using the new bolts and washers provided. Next, slip the spacer behind the upper bracket mounting hole and insert the new socket head cap screw with new washer through the bracket, through the spacer and loosely tighten all three bolts. (see figure 2) repeat steps 3 - 5 on the Clutch side. *Note: You will tighten these bolts after the windshield is installed on to the bushings.*

6. Install the windshield by placing the lower slots into the lower mounting bushings. Slip the upper slots into the upper mounting bushings and gently but firmly seat the slots into place. Lock the locking mechanism into place. (see figure 3 and 4)

7. Tighten all mounting bolts. Adjust the height, angle and alignment of the windshield and tighten ***ALL*** bolts.

Note: This is a detachable windshield, **ALWAYS** make sure the Locking Mechanism is Fully Engaged after installing the windshield! (see figure 4)

CAUTION

IMPORTANT CARE AND CLEANING INSTRUCTIONS

Memphis Shades Windshields and Lowers are made of Lucite® acrylic, and will last for years with proper care. Clean your windshield with plenty of soapy water — mild dishwashing liquid is best — and a soft cotton cloth. Use your bare hand to feel and dislodge bugs, or cover with a wet soapy towel and let it soak. Don't use paper towels and don't scrape with anything. Small scratches can be removed with NOVUS # 2.

NEVER use any glass cleaning products, petroleum based chemicals, or cleaning agents with ammonia, bleach or any other harsh chemicals. This includes (but not limited to) RainX, brake fluid, acetone, paint thinner, benzene and gasoline. "If it hurts your nose, it will hurt the plastic."

Glass cleansing agents will cause severe damage to your windshield, and will void your warranty.

NOTE: At certain times of the day the Sunlight can reflect off the curvature of a windshield and cause extreme heat build-up on motorcycle instruments and instrument panel. Take care when parking. Park facing the sun, place an opaque object over the instruments or adjust the windshield to avoid reflections.

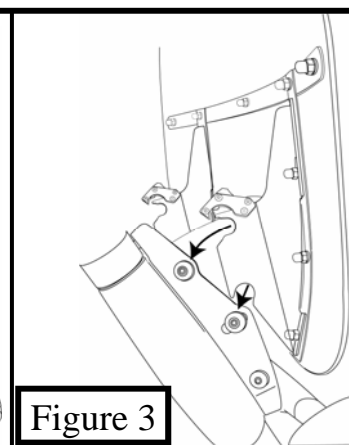
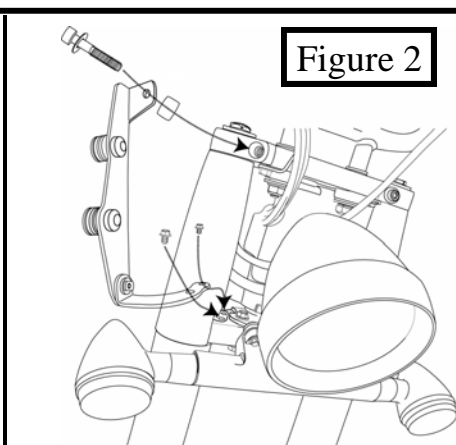
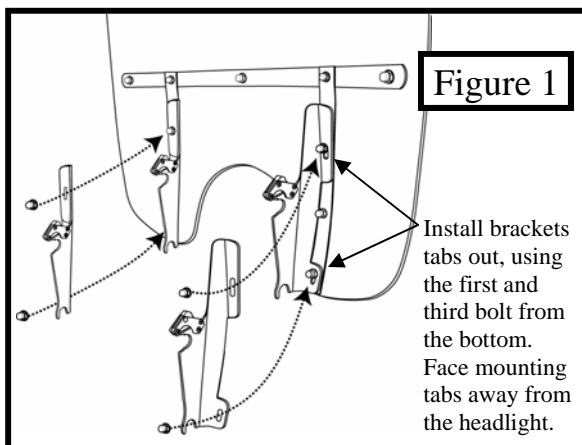



MOUNTING INSTRUCTIONS

2321-0051 FATS/SLIMS HONDA VT750 SHADOW AERO DETACHABLE

PART #	DESCRIPTION	QTY.
M8966	MOUNTING INSTRUCTIONS	1
M1123	LEFT F/S PLATE HONDA AERO	1
M1124	RIGHT F/S PLATE HONDA AERO	1
M1127	LEFT BRACKET HONDA AERO	1
M1128	RIGHT BRACKET HONDA AERO	1
M320	8mm X 45mm SOCKET HEAD CAP SCREW	2
M321	5/16" SS FLAT WASHER	4
M591	PINCH BOLT SPACER	2
R300	8mm X 16MM SS HEX HEAD SCREW	2
R302	1/4" SS FLAT WASHER	2
R301	6mm X 16MM SS HEX HEAD SCREW	2
R323	BUSHING ASSEMBLY (2 PART)	4
R318	1" SOCKET SHOULDER WASHER	4
R324	#207 EPDM O-RING	4
R321	1" INDENTED RECESSED SPACER	4

PART #	DESCRIPTION	QTY.
M301	1/4"-20 X 3/8" SOCKET HEAD CAP SCREW	2
M303	1/4"-20 X 3/4" SOCKET HEAD CAP SCREW	4
M306	1/4"-20 X 5/8" SOCKET HEAD CAP SCREW	2
M505	BUTTON NUT	4
R322C	CLUTCH SIDE LATCH ASSEMBLY	1
R322T	THROTTLE SIDE LATCH ASSEMBLY	1
R334	6-32 X 3/8" FLAT HEAD SS SCREW	8
R326	SS SPRING	2
R329	SLOT NUT	2
M310	3/16" SHORT ARM ALLEN WRENCH	1
M313	3/16" ALLEN WRENCH COVER	1
M311	6mm SHORT ARM ALLEN WRENCH	1

BUSHING ASSEMBLY

A. M505
B. R321
C. R323
D. R324
E. R318
F. M303
G. M306

F-Upper
G - Lower

1. M1128
2. M1124
3. M1127
4. M1123
5. R300
6. M321
7. R301
8. R302
9. M320
10. M591

Figure 3

1. Place lower slot into lower bushing. 2. Rotate top slot into place. 3. & 4. Secure locking Mechanism.

Figure 4

2321-0051 FATS/SLIMS KIT

R322C/T LATCH ASSEMBLY

NOT CORRECT **CORRECT Fully engaged**

Loosen Allen Bolt to adjust angle, then re-tighten Allen Bolt.

Memphis Shades warrants all product components, metal and plastic, against defects in materials and workmanship for 24 months.

FOR PARTS AND WARRANTY HELP, CONTACT:
 MEMPHIS SHADES
 P. O. Box 429
 Rossville, TN 38066
 (901) 853-0293
 Visit us on the web at www.memphisshades.com or
 you can also reach us at customerservice@memphisshades.com