

XK GLOW

MX-MOTO-STA



XKMAX MOTORCYCLE LED KIT
INSTALLATION INSTRUCTIONS



xk@xkglow.com

(217) 679-1915

INPUT VOLTAGE	CONTROLLER MAX LOAD	MAX POWER PER POD	MAX POWER PER 10" STRIP	MAX POWER PER 16" STRIP
11-14V	5A / CHANNEL	1W	2.2W	3.9W

WARRANTY AND DISCLAIMER

Within **THREE** years after the purchase date, the original buyer may return any **XKGLOW** lighting product that has failed due to a defect in materials or workmanship to receive a replacement product.

Installation of this product must be performed by a licensed professional. Should the failure of the product be the result of damage occurring as a result of improper installation, alteration of the product or an act or omission on the part of the consumer, this warranty is void. **XKGLOW** Lighting shall not be responsible for any consequential damages which arise from the use and/or installation of the product. If the kit is installed in any manner other than specified, **XKGLOW** Lighting reserves the right to deny any warranty claims at the discretion of the technical support department. Any product return must include the original packaging, invoice number and a statement of the alleged defect. Upon receipt of the returned product, the company will test the product for defect. If the results of the testing do not support the warranty claim, do not reveal any defect or indicate consumer negligence in the installation and handling of the product, then the product will be returned to you and you will be charged a reshipping fee. If the product is returned from an address within the continental United States, within the first 30 days after purchase, and is found to be defective, **XKGLOW** Lighting will exchange or refund the original purchase expense. This offer does not extend to the cost for shipping charges on any international packages.

ADDITIONAL DISCLAIMER TERMS

Please check your local and state laws for the proper use of this product.

- Improper installation of electrical products such as lighting may cause damage to any vehicle or device to which the improperly handled or installed lighting is attached.
- Improperly installed product may cause electrical injury to persons.
- It is recommended that the kit should be installed by a licensed professional.
- **XKGLOW** assumes no liability for the installation of the product.
- Warranty or liability will not exceed the product purchase price, which shall be buyer's sole and exclusive remedy.

RETURN/EXCHANGE PROCEDURE

1. Email [xk@xkglow.com] to notify us of the product issue as well as the item number and name of customer on invoice.
2. We will send you the trouble-shooting guide to fix the issue, or to narrow down which of the component(s) need to be replaced. If the issue still exists, we will ask you to send back the defective items to be replaced.
3. Please send the returned item as instructed, along with claims and a telephone number where you can be reached.
4. After the returned item(s) have been accepted and inspected, we will issue a refund or replace the items ASAP. For refunds, item(s) must be sent to **XKGLOW** within 30 days from date of purchase. Original shipping charges are not refundable.

We always stand behind our products and are committed to our customers! For questions you may have, please contact xk@xkglow.com. We normally respond within 24 hours. (Monday-Friday).



MOUNTING INSTRUCTIONS

1. Test all components before mounting: As shown below, plug ALL light units together and connect them to the controller and the switch wiring harness. Connect the **RED** battery terminal to the **POSITIVE** pole of 12V DC battery. Connect the **BLACK** battery terminal to the **NEGATIVE** pole. Turn on the switch and push the **touch button** to test all lights. If the lights show any defects, please contact us and we will be happy to replace them for you.

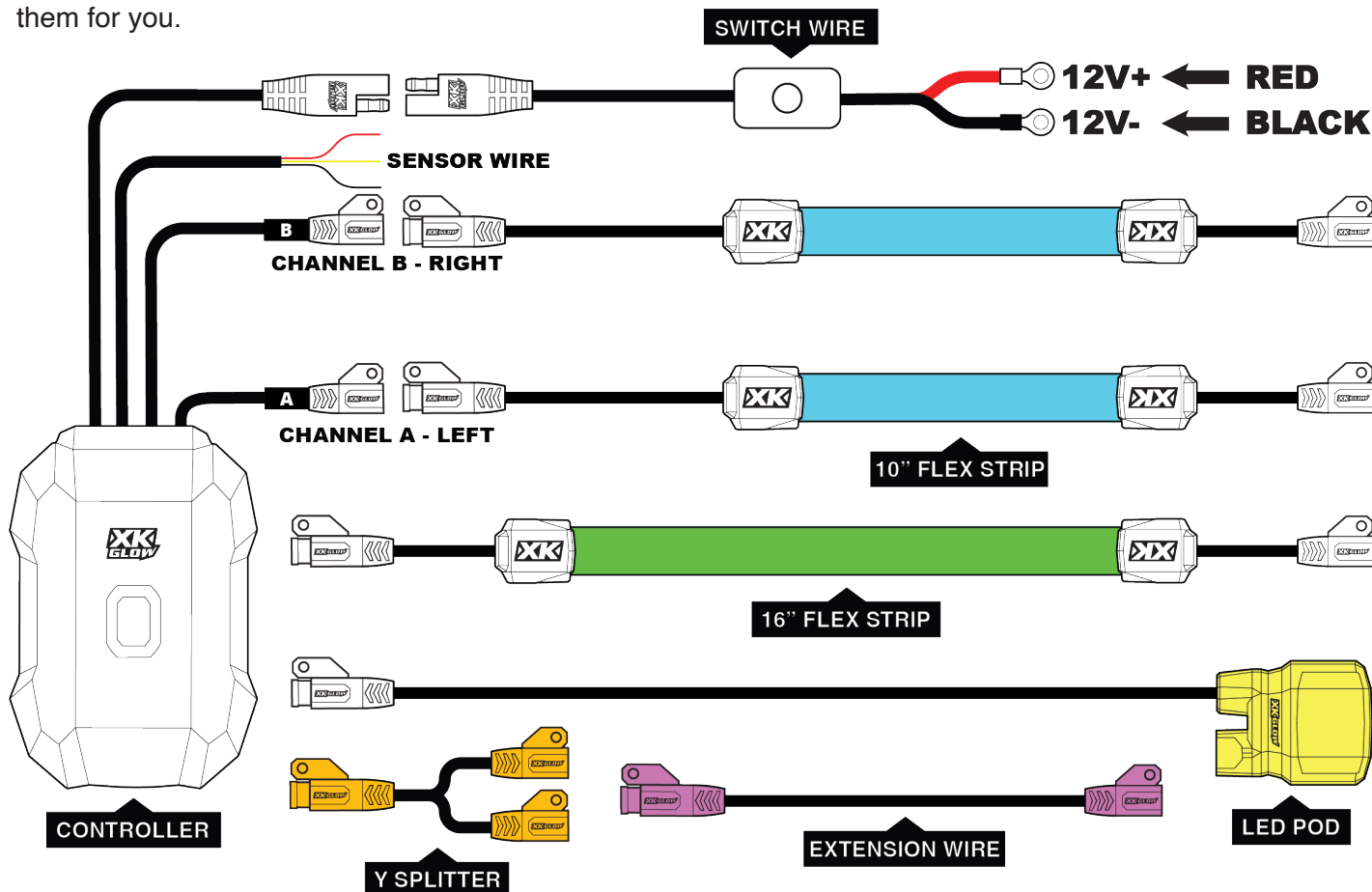

2. Plan Mounting Locations: Disconnect the tested lights from the vehicle's battery and remove any bodywork that will have the LED lights located behind them. **Planning your install is the most important part of getting the best light effect in the end.** If the lights are placed randomly and without thought, the gradients and patterns will not flow along the motorcycle properly. Note that **Channel A** is for the **left** side of the motorcycle and **Channel B** is for the **right** side of the motorcycle.

Page 4 includes recommended mounting locations for both cruisers and for sport bikes. The controller comes pre-configured based on the diagrams on Page 4. To get the best possible light effect with the stock settings, the lights must be installed as close to the diagram as possible paying close attention to wiring and strip orientation.

Following the recommended locations, **LOOSELY** mount the LED lights using Scotch or painters tape (not included) to the desired locations. (DO NOT firmly attach the lights in this step.) Connect extension wires to plug in all the lights. Test chasing light patterns to ensure smooth transitions in the mounted locations. Adjust lights as necessary.

CRUISER INSTALL-

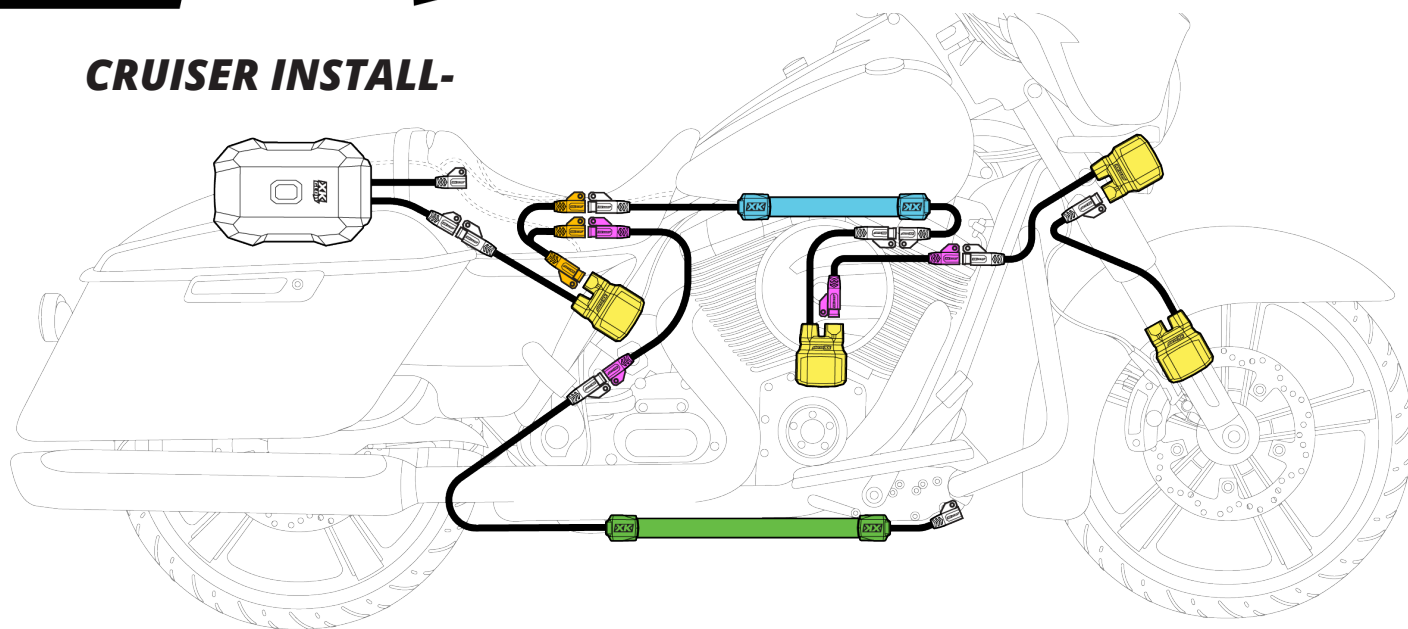

SPORT BIKE INSTALL-

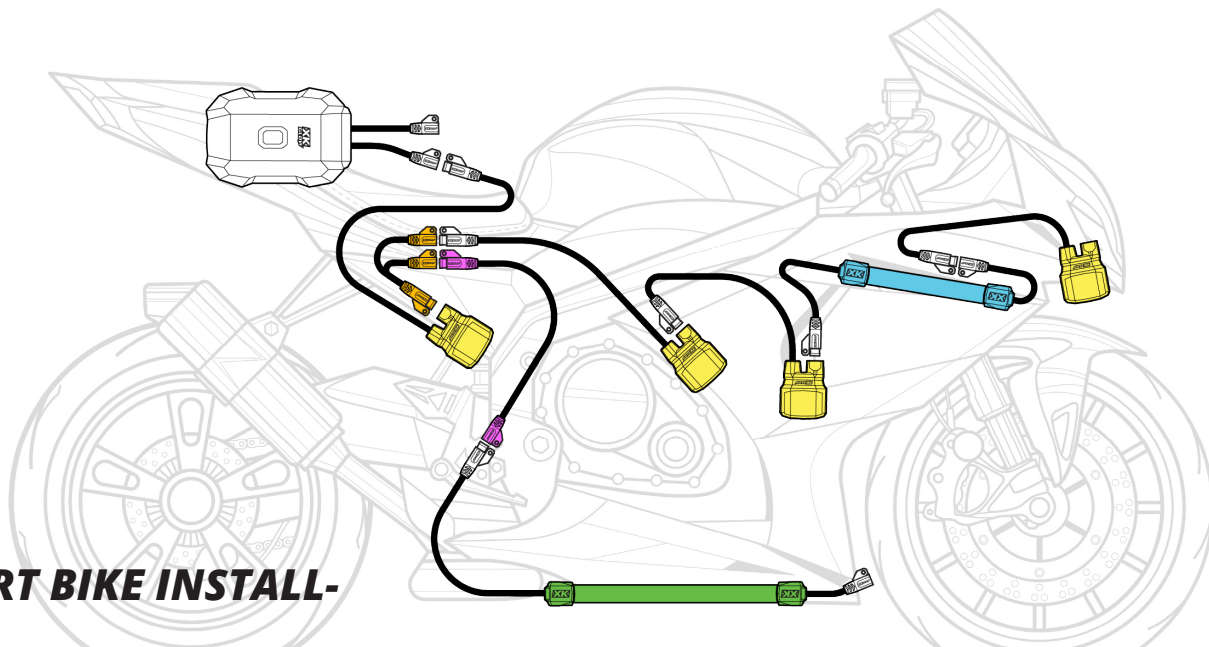

3. Mount the Lights: After testing and confirming the light patterns, the lights can be permanently mounted. Use isopropyl alcohol to wipe the mounting surface clean. Peel back the 3M tape and firmly press the strips and pods into place. Connect all extension wires and the switch wiring harness. **WARNING-** Do not force the plugs together! If they don't snap together, verify that all the pins line up. If a pin is out of place, it must be straightened up for the plug to snap together.

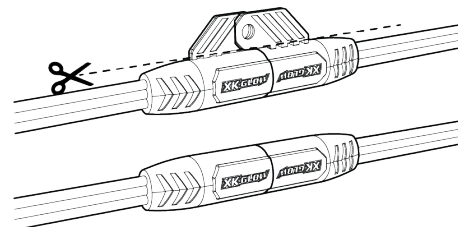
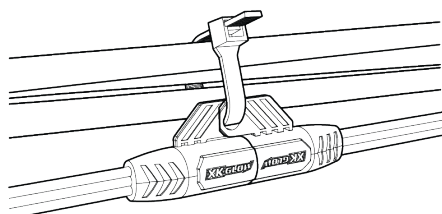
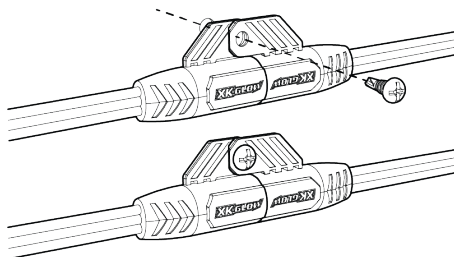

FULLY CUSTOMIZED INSTALL

If you followed the suggested diagrams for your install and everything is lighting up, you can skip this section.

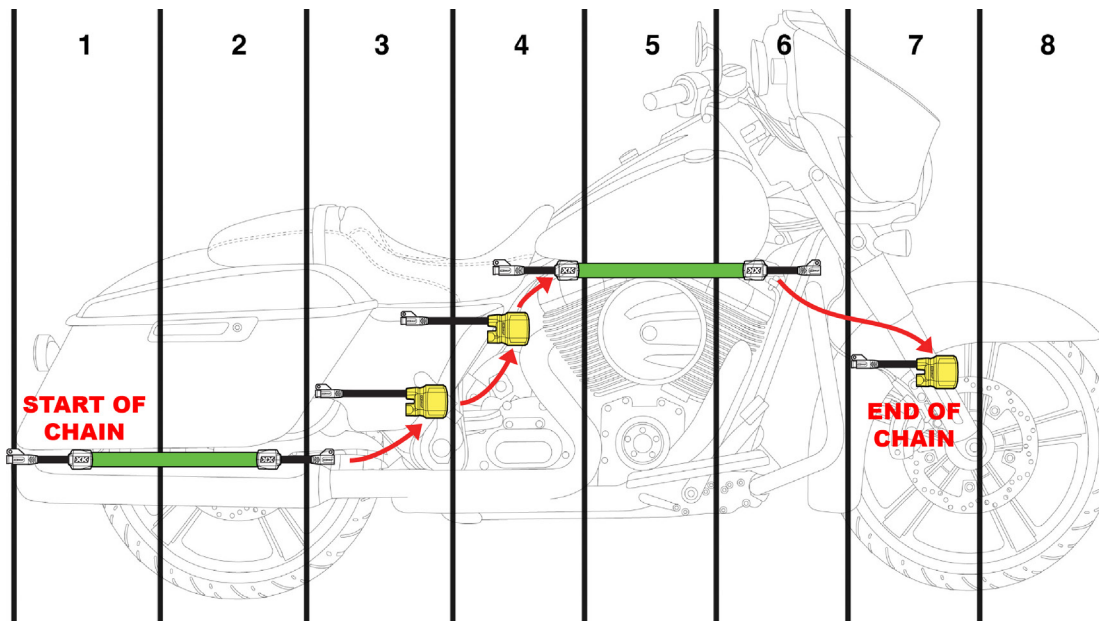

The diagrams on Page 4 are a recommendation but the lights can be installed wherever you would like. However, to achieve the best possible light effect with the chasing LEDs, the lights should be installed in a specific manner. The lights are installed “daisy chain” style meaning one light is plugged into the controller, the 2nd light is plugged into the first light, and so on. The lights should start at the rear of the motorcycle and then extend forward.

See diagram above. If the first strip is in section 1 and 2, try to mount the next light in section 3, then in section 4, and so on with the last light in the daisy chain ending at the highest number section, shown as 7 in this example. The goal is to get the lights to flow from the rear of the motorcycle to the front of the motorcycle for the best chasing effect.

Y-SPLITTERS

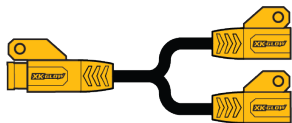

You can use Y-splitters to split off the daisy chain into 2 or more strands. Please note that after the Y-splitter, any light effect will mirror on each new daisy chain. Example- if you have 1 strip on split 1 and 1 strip on split 2, those strips will always show the same color or pattern as the adjacent light. This can be used to keep the chasing effect flowing properly when you have lights under the gas tank and under the frame rails.

CONFIGURE YOUR KIT

If you went with a universal install and some pods or strips are not lighting up, you must reconfigure your light diagram in the XKmax App for proper operation and best light effect. Open up the XKmax App and follow the on screen instructions to pair to the controller. First, clear the light map-

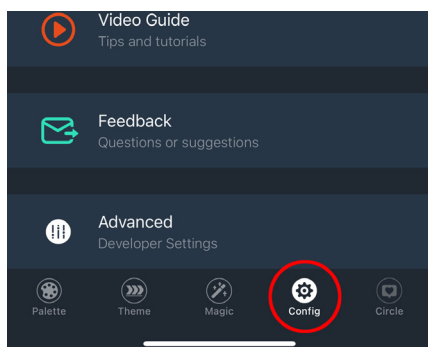

Tap the Config. icon.

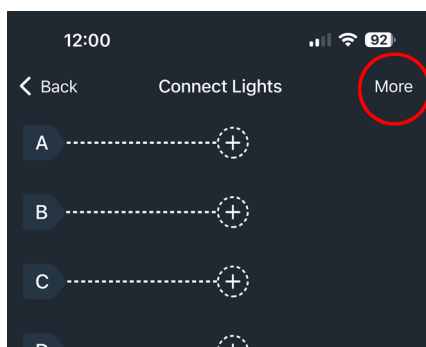

Click More in the top right corner.

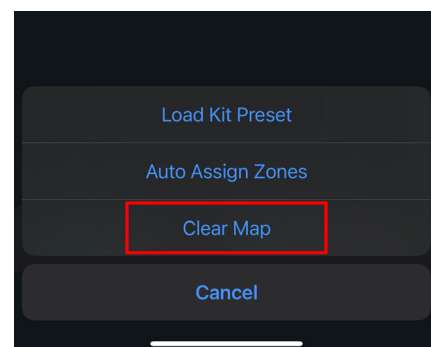

Click Clear Map.



Count addressable units: If you are using Y-splitters, you must figure out which strand after the Y-splitter has the greatest number of addressable units. If you are not using Y-splitters, you can skip this step.

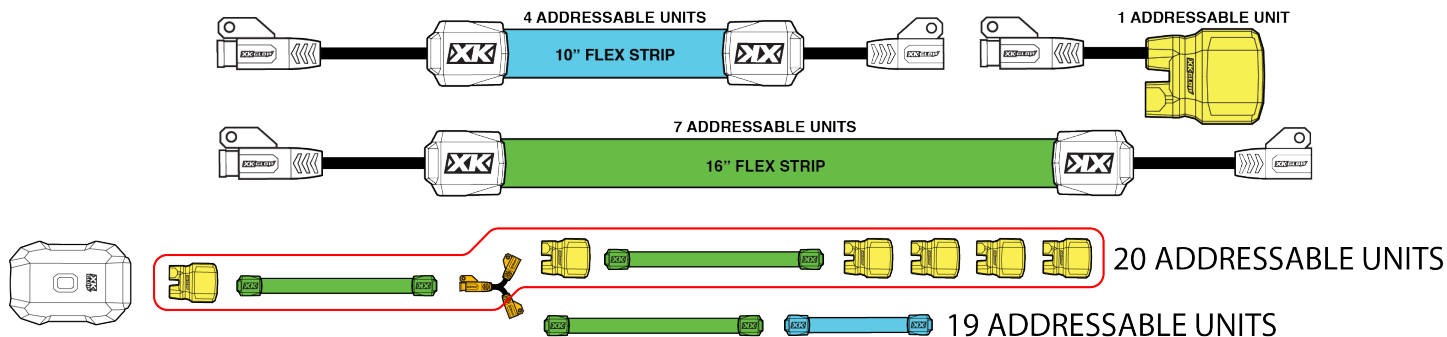

Draw out your light map and add up the addressable units. In the example above, we have one strand with a total of 20 addressable units and another with 19 total addressable units. We will use the greater number (20 - shown in red) to map out our light kit in the App.

Configure light map:

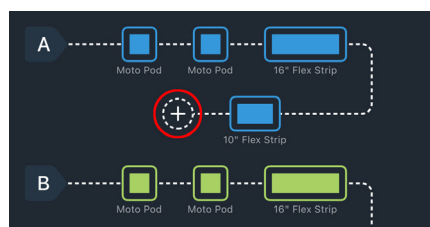

In the Config. page, tap the + icon to add your lights. Reference wiring diagram in your instructions to see which wire corresponds to which zone.

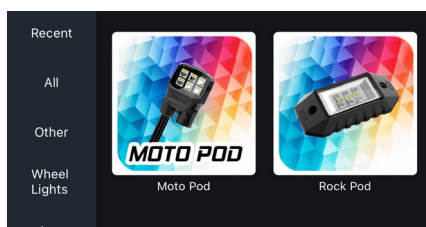

Select your lights to add to each Channel. The icon for each light will appear on your light map as you add them.

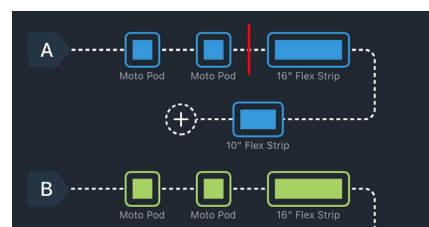

Drag a light icon to rearrange or Delete. Click a chasing line between lights to separate zones.

4. Secure all wires and connectors: Use provided screws or zip ties to neatly mount and hide any loose wires. The tabs can also be cut off to help the wire fit through tight spaces. Make sure they are not touching anything hot or located on moving parts. Install the ON/OFF switch in a dry and convenient location. Use provided end caps to cover all uncovered connectors.

5. Tap sensor wires: (Optional) If you tap the sensors as specified, the triggered action has already been setup in the controller. However, you can use it to other functions such as courtesy light and customize the triggered actions in Config --> Sensor Wires section. If you would like to use the lights as turn signals and brake, refer to the diagram to the right. Remember what color wire is attached to which function, as you will select the sensor wire color in the app to assign a light sequence. Use diagram below to tap wires using included T-tap connectors.

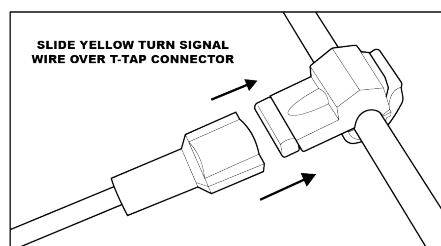
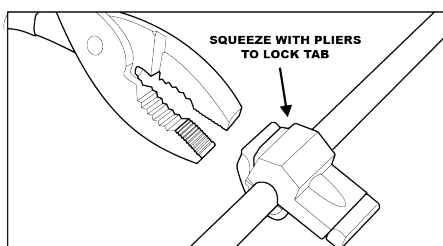
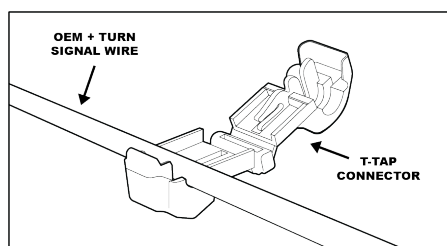
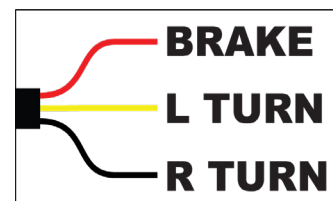

6. Connect to 12V DC power: Firmly connect the wire terminals to the positive and negative poles of the battery. Power on and test the lights.

DOWNLOAD XKMAX

Scan the QR code below to download the XKmax App



 App Store



 Google Play

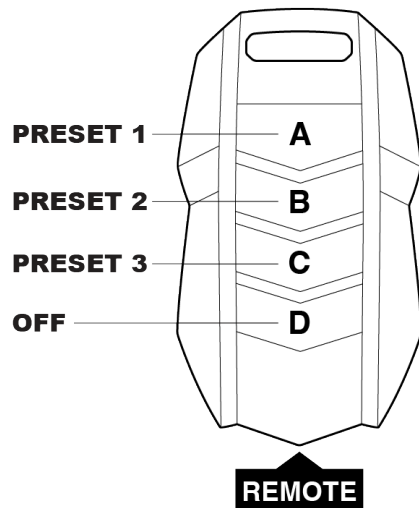

Buttons customizable. See App Instructions.

LOAD YOUR KIT PRESET



MX-MOTO-STA

NEED MORE LIGHTS?



UPGRADE ACCESSORIES

PRODUCT FEATURES



+ INSTALL VIDEOS

MONTHLY PHOTO CONTEST:
POST YOUR BEST PHOTO OR VIDEO FOR A CHANCE TO WIN \$150!

JOIN THE CIRCLE!
CREATE. CONNECT. COMMUNITY.